

Compact Machining Center
SPEEDIO™

brother®
at your side

NEW

S500X1
S700X1

brother

SPEEDIO S500X1

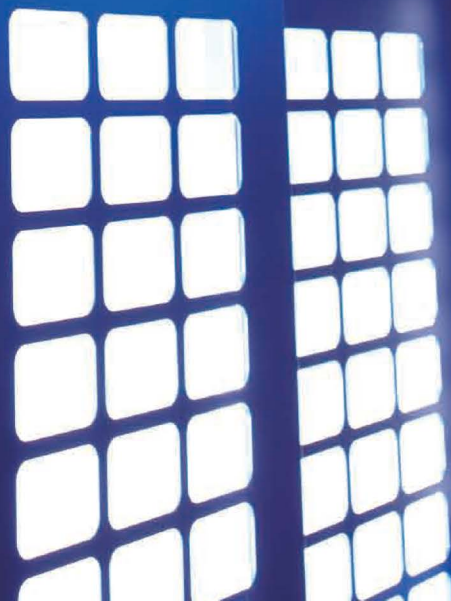

SPEEDIO™



SPEEDIO™

The compact machining center SPEEDIO has been released, achieving overwhelming productivity and excellent environmental performance based on Brother's original technologies. Our efforts have been focused on releasing a machine that brings about success to users producing mass-production parts, in response to their deep confidence.





Photos show machines with a 21-tool magazine. The magazine cover is not provided for machines with a 14-tool magazine.

SPEEDIO™ S500X1

SPEEDIO™ S700X1



Basic specifications	Max. spindle speed(min ⁻¹)	10,000 10,000 high-torque (Optional) 16,000 (Optional) 27,000 (Optional)
	Stroke of each axis(mm)	S500X1 X 500 Y 400 Z 300 S700X1 X 700 Y 400 Z 300
	Tool storage capacity(pcs.)	14 / 21
	Rapid traverse rate(m/min)	X / Y / Z 50 / 50 / 56
	Required floor space(mm)	S500X1 1,560×2,220 S700X1 2,050×2,220
	BT dual contact spindle(BIG-PLUS)	Optional
	Coolant Through Spindle(CTS)	Optional

* CTS option is not available for 27,000 min⁻¹ specifications.



Pursuit of higher productivity

The machine has achieved overwhelming high productivity as a result of achieving high acceleration and quick response. In particular, Z-axis acceleration has been greatly improved, which is highly effective for improvement of productivity.

Achievement of high acceleration

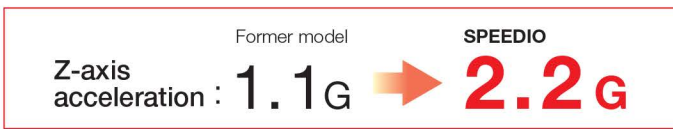

As the Z-axis moves most frequently, Z-axis acceleration has been improved to twice the former model.

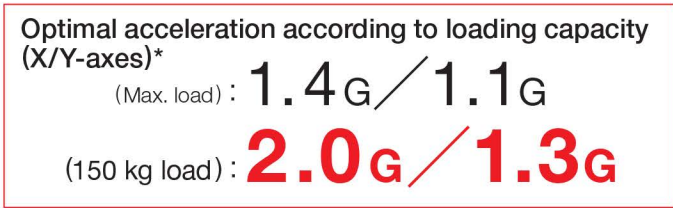

The X/Y-axes optimal acceleration setting function sets the most appropriate acceleration according to the table loading capacity.

* Acceleration for the S500X1. The loading capacity needs to be set via parameter.

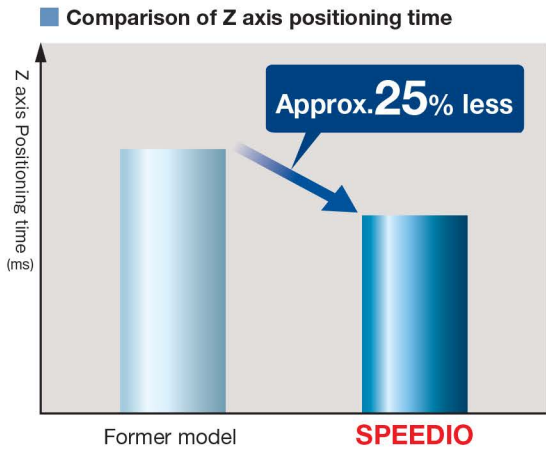

* When moving from Z-axis home position to stroke center

Highly-responsive servo motor

Delay in response has been reduced to almost zero by increasing the responsiveness of the servo motor. For example, high-speed synchronized tapping at the fastest level in the world is completed within much shorter time.

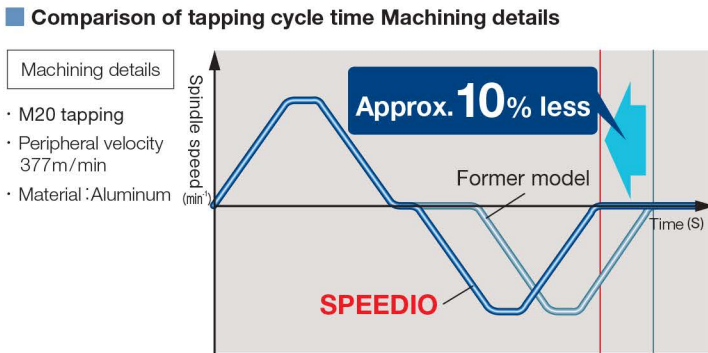

* Data taken by running machining program created by Brother

Optimized waste elimination control

Brother's original NC unit thoroughly eliminates waste motion and waste time, and drives machine performance to the fullest to demonstrate high productivity.

Nonstop ATC

Tool change time is minimized by optimizing the magazine operation and improving the Z-axis acceleration, in addition to the shorter start and stop time of the spindle.

	Former model	SPEEDIO
Chip - Chip :	1.6s	1.4s
Tool - Tool :	0.9s	0.8s

Simultaneous operation control

Further reduction of waste time achieved by positioning X/Y and additional axes simultaneously with tool change.

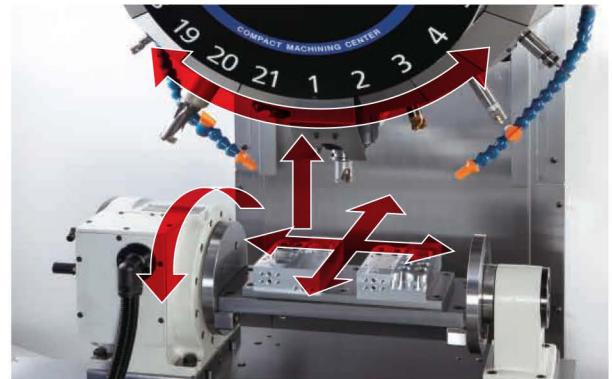

When compared to a general machining center (M/C), the high productivity of the SPEEDIO is outstanding. Brother is constantly pursuing overwhelmingly high productivity.

Conditions for productivity comparison

Major machining details	<ul style="list-style-type: none"> · D5.1 drilling × 12 · Boring × 2 · M6 tapping × 12 · No. of tools used : 9 · Spot facing × 7
	<ul style="list-style-type: none"> Workpiece change time : 15s 1day (10hours) × 85% operating rate

Comparison of productivity

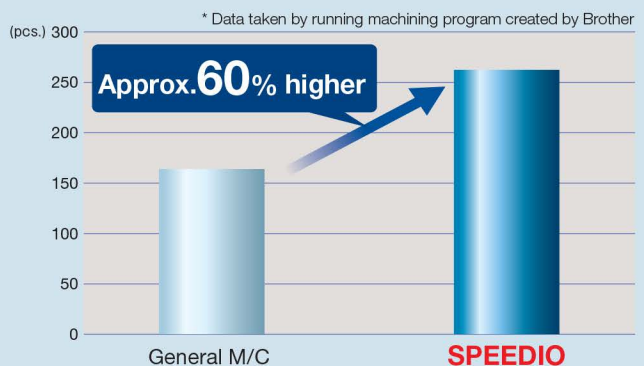



From high-speed, high-efficiency machining to heavy-duty machining

Technologies accumulated over years to enhance machine rigidity, and use of a high-power spindle motor allow the machine to demonstrate its broad machining capabilities from high-speed, high-efficiency machining to heavy-duty machining.

Highly rigid structure

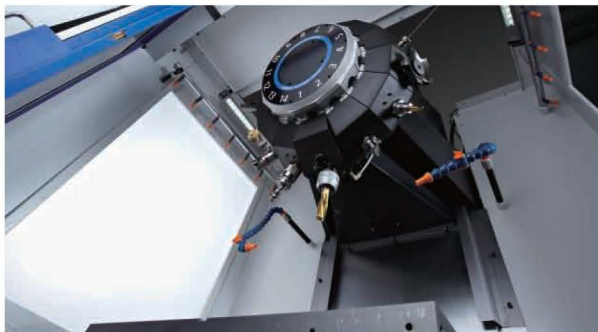

Based on accumulated analysis technology data, the machine uses a structure that effectively further improves its rigidity.

**Z-axis rigidity
15% increase**

For the Z-axis in particular, the stress path is reduced, leading to improvement of rigidity by approximately 15%.

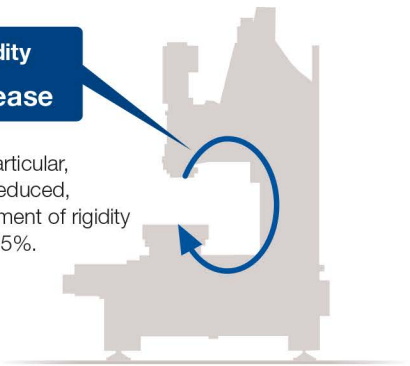

High-power spindle motor

Medium- and high-speed range enabling high-efficiency machining



Grooving using standard specs
Machining details Cutting amount: 150cc/min
Material: Carbon steel
(for ø16 end mill)

Low-speed range suitable for heavy-duty machining



Large hole drilling using high-torque specs
Machining details Hole diameter: ø40mm
Material: Carbon steel

Spindle motor torque

Standard specs

Max. torque (momentary): **40 Nm**

Max. output: **18.9kW**

High-torque specs (Optional)

Max. torque (momentary): **92 Nm**

Max. output: **26.2kW**

Pursuit of high-accuracy machining through machine/controller integrated development

High-accuracy machining has been achieved by improving machine rigidity, renewing the control system using a new NC unit, and adding new functions. Stable accuracy for circular machining and three-dimensional machining has also been achieved.

Pursuit of high accuracy

Resolution of the encoder has greatly improved and various offset functions have been added. These improvements achieve high accuracy for circular machining and pitch machining. The machine structure used is not easily affected by heat expansion due to coolant.

● Circular machining Roundness: **30% better**
(compared to former model)

Diameter: $\Phi 80\text{mm}$ Material: Aluminum

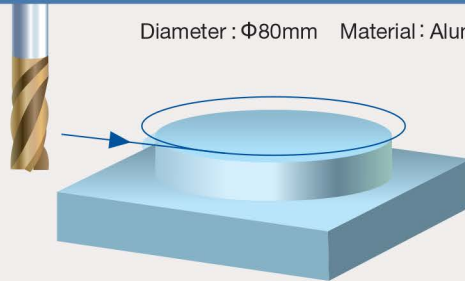

* This accuracy may not be obtained under some machining conditions, machine installation conditions etc.

High-speed three-dimensional machining

High-speed and highly accurate three-dimensional machining has been achieved by high-speed spindle specifications and Brother's original three-dimensional machining control, such as the 200-block look-ahead function and smooth path offset function.

High-speed spindle specs: (Optional) Max. spindle speed **27,000 min^{-1}**

Look-ahead function
High accuracy mode BI (Standard): **30 blocks**
High accuracy mode BII (Optional): **200 blocks**





Equipped with new CNC-C00 control unit

The machine is equipped with the CNC-C00 series next generation NC unit with greatly improved processing capabilities and functions, and enhanced usability.

Operability

Equipped with 'shortcut' keys to quickly open the desired screen and 'sub folder' to make program management easier, in addition to the USB memory interface, menu programming and tap return function.



Shortcut keys

Network function

High capacity program data can be transferred via Ethernet at high speed. The simple production monitoring function is also available allowing you to monitor the machine's status.

PC

Ethernet



(Production monitor screen)

Machining support functions

Equipped with machining support functions, such as torque waveform display, high accuracy mode, and heat expansion compensation system.

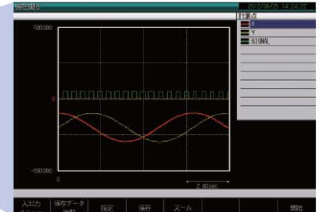

Maintenance functions

Equipped with motor insulation resistance measurement, operation log, and maintenance notice function.



System capacity

Standard equipped with PLC. Input and output points can be extended to up to 1024 points each (Optional).

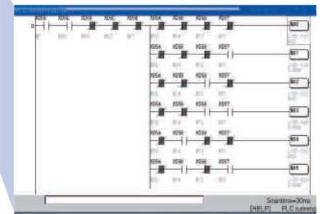

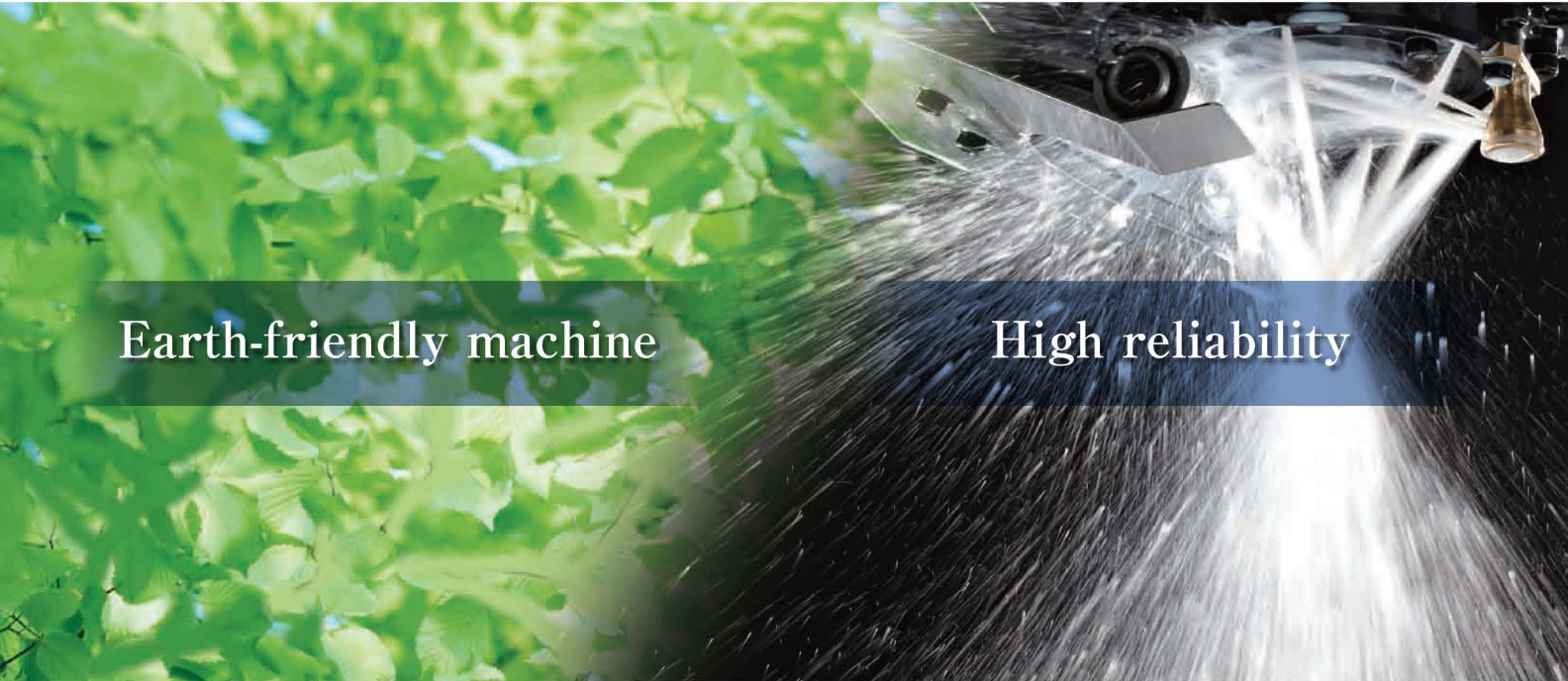

Earth-friendly machine

High reliability

Lower power and air consumption ensures high environmental performance.
A power regeneration system that effectively lowers power consumption is used for all models.

Low power consumption is achieved by using an energy saving pump etc. in addition to a low-inertia spindle and high-efficiency motor.

Power consumption for one cycle

* Data taken by running machining program created by Brother

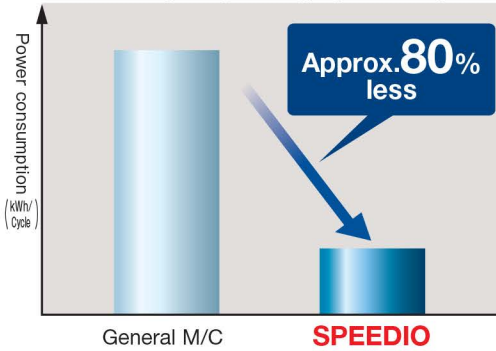

LED type work light (Optional)



Energy saving pump

The SPEEDIO is an earth-friendly machine equipped with a variety of energy-saving functions.

- Automatic coolant off — Turns off the coolant pump when the preset time elapses.
- Standby mode — Turns off the servomotor when the machine is not operated for the preset time.
- Automatic work light off — Turns off the work light when the preset time elapses.
- Automatic power off — Turns off the power at the preset time.

Reliable functions that enhance productivity, minimizing defects and preventing failure

Productivity can also be enhanced from the following viewpoints: “prevent dimensional defects” and “prevent machine failure with minimal maintenance to minimize machine down time”. The SPEEDIO is equipped with functions to achieve these.



Air-assisted tool washing (Optional)

High discharge pressure prevents chips becoming attached to the holder.

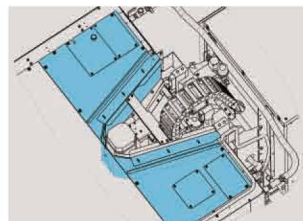

Top cover (Optional)

Separates the machining area from the machine room.

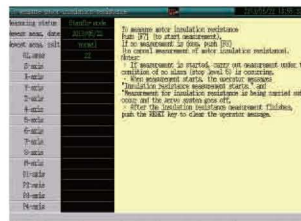

Motor insulation resistance measurement function

Detects motor failure in advance.

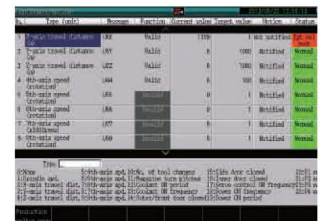

Maintenance notice function

Notifies operators of when greasing is required etc.



Coolant unit

Can be selected from 50L, 100L, or 150L, depending on the purpose.
(Photo: Tank with 150L chip shower)



Coolant Through Spindle (CTS)

1.5 MPa CTS used for BT spindle.
* Please consult Brother for use of 3 MPa CTS.
* CTS option is not available for 27,000min⁻¹ specifications.

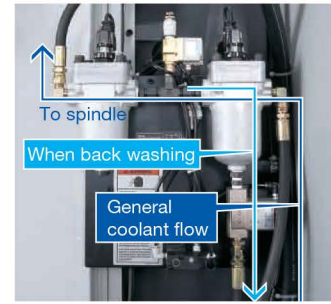

Back washing system (for CTS)

This prevents the filter from clogging, enabling long continuous operation without filter replacement.



Tool washing (air-assisted type)

High discharge pressure and flow rate efficiently remove chips attached to the holder. Equipped with a filter clog warning function.



Chip shower

Chip shower pipes are located at the upper section inside the machine for more efficient flow, and flexible shower nozzles can be directed to the side of the machine cover or sections where chips tend to accumulate.

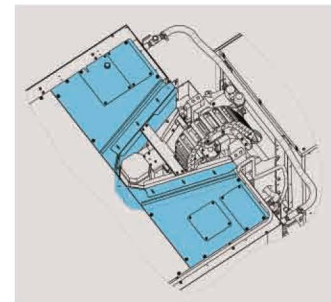

Top cover

Shutting the opening on the top prevents coolant or chips splashing outside of the machine, and reduces the effect of there on the spindle motor.

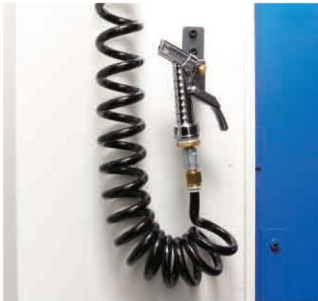

Cleaning gun

Helps clean the workpiece or chips inside the machine after machining.



LED type work light (1 or 2 lamps)

LED lamps are used to extend lamp life and save energy.



Indicator light (1, 2, or 3 lamps)

LED lamps are used. There are no bulbs to burn out, making it completely maintenance free.



Side cover (transparent board type)

External light is drawn in to make the inside of the machine brighter and improve visibility.



Automatic door (motor-driven)

A motor-driven door is used, achieving smooth operation.



Automatic grease lubricator

Regularly greases all greasing points on the three axes.
* Manual greasing applies to the standard specification model.



High accuracy mode BII (look-ahead 200 blocks)

The 200-block look-ahead function enables high-speed and highly accurate three-dimensional machining. Also equipped with a smooth path offset function to improve machining quality.



Tool breakage detector (touch type)

A touch switch type tool breakage detector is used.



Manual pulse generator

Manual pulse generator with a cable makes operation through the maintenance window easier.



Spindle override

Spindle speed can be changed without changing the program.



B-axis cord (for 1 axis, 2 axis)

Multi-face machining is possible by adding one or two axes.



RS232C (25 pin)

Conventional 25-pin connector can be attached to the side of the control box.

Optional

Standard

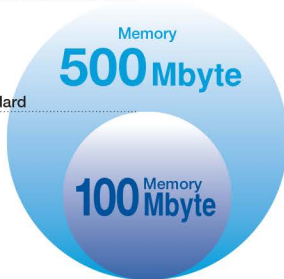

Memory expansion

Memory can be expanded to up to 500 Mbytes.



Switch panel (6 holes, 10 holes)

The position of the manual pulse generator can be changed using the switch hole, avoiding the generator being positioned behind the roller conveyor or similar.

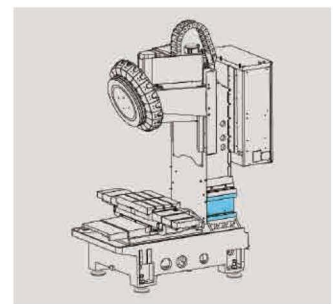

High column (150mm, 250mm)

High column of 150mm and 250mm used in response to customers' needs.

Optional Specifications

- Coolant unit
 - ① 50L (with valve and 180W pump)
 - ② 100L (with chip shower, valve and 250W + 250W pumps)
 - ③ 150L (with chip shower, valve and 250W + 400W pumps)
 - ④ 150L (with chip shower, CTS, valve and 250W + 400W + 650W pumps)
- Coolant Through Spindle (CTS)
- Mesh basket for chips
- Tool washing (air-assisted type)
- Tool breakage detector (touch type)
- Chip shower
- Cleaning gun

* When the submicron command is used, changing to the conversation program is disabled.

- Jig shower valve unit
- Back washing system (for CTS)
- Automatic oil lubricator
- Automatic grease lubricator
- LED type work light (1 or 2 lamps)
- Indicator light (1, 2, or 3 lamps)
- Automatic door (motor-driven)
- Area sensor
- Specified color
- Manual pulse generator
- B-axis cord (1 axis, 2 axes)
- Spindle override
- High column (150 mm, 250 mm)
- Grip cover
- Top cover

- Side cover (transparent board type)
- RS232C (25 pin) for control box
- Expansion I/O board (EXIO board)
 - ① EXIO board assembly
 - ② Additional EXIO board assembly
- Switch panel (6 holes, 10 holes)
- Memory expansion (approx. 500 Mbytes)
- High accuracy mode BII (look-ahead 200 blocks, smooth path offset)
- Submicron command *
- Interrupt type macro
- PLC programming software (for Windows®XP, Vista, and 7)

Windows® is a trademark or registered trademark of Microsoft Corporation in the United States and/or other countries.
* Please contact your Brother dealer for details.



Item		S500X1	S700X1
CNC Unit		CNC-C00	
Travels	X axis mm (inch)	500(19.7)	700(27.6)
	Y axis mm (inch)	400(15.7)	
	Z axis mm (inch)	300(11.8)	
	Distance between table top and spindle nose end mm (inch)	180~480(7.1~18.9)	
Table	Work area size mm (inch)	600x400(23.6x15.7)	800x400(31.5x15.7)
	Max.loading capacity (uniform load) kg (lbs)	250[300 *6] (551[661 *6])	
Spindle	Spindle speed min ⁻¹	10,000min ⁻¹ specifications : 10~10,000 16,000min ⁻¹ specifications (Optional) : 16~16,000 10,000min ⁻¹ high-torque specifications (Optional) : 10~10,000 27,000min ⁻¹ specifications (Optional) : 27~27,000	
	Speed during tapping min ⁻¹	MAX. 6,000 (27,000min ⁻¹ specifications : MAX. 8,000)	
	Tapered hole	7/24 tapered No.30	
	BT dual contact system (BIG-PLUS)	Optional	
Feed rate	Coolant Through Spindle (CTS)	Optional (CTS option is not available for 27,000min ⁻¹ spec.)	
	Rapid traverse rate (XYZ-area) m/min(inch/min)	50 x 50 x 56(1,969 x 1,969 x 2,205)	
	Cutting feed rate mm/min(inch/min)	X, Y, Z: 1~30,000 (0.04 ~ 1,181) *7	
ATC unit	Tool shank type	MAS-BT30	
	Pull stad type *4	MAS-P30T-2	
	Tool storage capacity pcs.	14 / 21	
	Max. tool length mm (inch)	250(9.8)	
	Max. tool diameter mm (inch)	110(4.3)	
Tool change time *5	Max. tool weight *1 kg (lbs)	3.0(6.6) / Tool (TOTAL TOOL WEIGHT: 25(55.1) for 14 tools, 35(77.2) for 21 tools)	
	Tool selection method	Random shortcut method	
	Tool To Tool sec.	0.8	
	Chip To Chip sec.	1.4	
Electric motor	Cut To Cut sec.	1.2	
	Main spindle motor (10min / continuous)*2 kW	10,000min ⁻¹ specifications : 10.1 / 6.7 16,000min ⁻¹ specifications (Optional) : 7.4 / 4.9 10,000min ⁻¹ high-torque specifications (Optional) : 12.8 / 8.8 27,000min ⁻¹ specifications (Optional) : 8.9 / 6.3	
Power source	Axis feed motor kW	1.0(X, Y), 2.0(Z)	
	Power supply	AC V±10%, 50/60Hz±1Hz	
	Power capacity (continuous) kVA	10,000min ⁻¹ specifications : 9.5 16,000min ⁻¹ specifications (Optional) : 9.5 10,000min ⁻¹ high-torque specifications (Optional) : 10.4 27,000min ⁻¹ specifications (Optional) : 9.5	
Air supply	Regular air pressure MPa	0.4~0.6 (recommended value : 0.5MPa *8)	
	Required flow L/min	45 (27,000min ⁻¹ specifications : 115)	
Machining dimensions	Height mm (inch)	2,497(98.3)	
	Required floor space [with control unit door open] mm (inch)	1,560x2,220 [2,692] (61.4x87.4 [106.0])	2,050x2,220 [2,692] (80.7x87.4 [106.0])
	Weight (including control unit, machine cover) kg (lbs)	2,250(4,960)	2,400(5,291)
Accuracy *3	Accuracy of bidirectional axis positioning (ISO230-2:2006) mm (inch)	0.006~0.020 (0.00024 ~ 0.00079)	
	Repeatability of bidirectional axis positioning (ISO230-2:2006) mm (inch)	Less than 0.004 (0.00016)	
Front door		2doors	
Standard accessories	Instruction Manual (1 set), anchor bolts (4 pcs.), leveling bolts (4 pcs.), machine cover (manual door)		

*1. Actual tool weight differs depending on the configuration and center of gravity. The figures shown here are for reference only. *2. Spindle motor output differs depending on the spindle speed. *3. Measured in compliance with ISO standards and Brother standards. *4. Brother specifications apply to the pull studs for CTS. *5. Measured in compliance with JIS B6336-9 and MAS011-1987. *6. Acceleration must be adjusted for X and Y axes. *7. When using high accuracy mode B. *8. Regular air pressure varies depending on the machine specifications, machining program details, or use of peripheral equipment. Set the pressure higher than the recommended value.

NC unit specifications	
CNC model	CNC-C00
Control axes	5 axes (X, Y, Z, two additional axes)
Simultaneously controlled axes	Positioning 5 axes (X, Y, Z, A, B)
	Interpolation Linear: 4 axes (X, Y, Z one additional axis) Circular: 2 axes Helical/conical: 3 axes (X, Y, Z)
Least input increment	0.001mm, 0.0001inch, 0.001 deg.
Max. programmable dimension	±9999.999mm, ±999.9999inch
Display	12.1-inch color LCD
Memory capacity	Approx. 100 Mbytes (Total capacity of program and data bank)
External communication	USB memory interface, Ethernet, RS232C 1ch
No. of registrable programs	4,000 (Total capacity of program and data bank)
Program format	NC language, conversation (changed by parameter) conversion from conversation program to NC language program available

*When program size is bigger than 2 Mbytes, machine works with extended memory operation.
*Ethernet is a trademark or registered trademark of XEROX in the United States.

Standard NC functions		
<ul style="list-style-type: none"> ● Absolute / incremental ● Inch / metric ● Corner C / Corner R ● Rotational transformation ● Synchronized tap ● Coordinate system setting ● Dry run ● Restart ● Backlash compensation ● Pitch error compensation ● Raid traverse override ● Cutting feed override ● Alarm history (1,000 pieces) ● Startus log ● Machine lock ● Computer remote ● Built-in PLC ● Motor insulation resistance measurement ● Operation log ● High accuracy mode BI (look-ahead 30blocks) 	<ul style="list-style-type: none"> ● High-accuracy mode AIII ● Tool length measurement ● Tool life management / spare tool ● Background editing ● Graphic display ● Subprogram ● Helical / conical interpolation ● Tool washing filter with filter clogging detection ● Automatic power off (energy saving function) ● Servomotor off standby mode (energy saving function) ● Chip shower off delay ● Automatic coolant off (energy saving function) ● Automatic work light off (energy saving function) ● Heat expansion compensation system II (X, Y, Z axes) ● Tap return function ● Automatic workpiece measurement *1 ● Waveform display ● Operation level ● External input signal key 	<p>(NC)</p> <ul style="list-style-type: none"> ● Expanded workpiece coordinate system ● Scaling ● Mirror image ● Menu programming ● Program compensation ● Tool length compensation ● Cutter compensation ● Macro function ● Local coordinate system ● One-way positioning ● Operation in tape mode <p>(Conversation)</p> <ul style="list-style-type: none"> ● Operation program ● Schedule program ● Automatic tool selection ● Automatic tool length compensation setting ● Automatic cutter compensation setting ● Automatic calculation of unknown number input ● Machining order control
Optional NC functions		
<ul style="list-style-type: none"> ● Memory expansion (Approx. 500 Mbytes) ● High accuracy mode BII (look-ahead 200 blocks, smooth path offset) ● Spindle override 	<ul style="list-style-type: none"> ● Submicron command *2 ● Interrupt type macro 	

*1. Measuring instrument needs to be prepared by users. *2. When the submicron command is used, changing to the conversation program is disabled.
*Functions listed under (NC) and (Conversation) are available only for NC programs and conversation programs respectively.

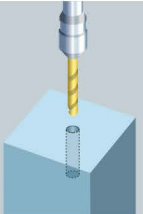
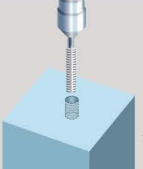
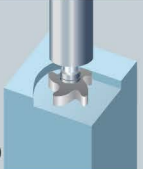

Machining capability

		ADC	FC200	S45C
■ Drilling  Tool diameter mm (inch) × Feed mm (inch)/rev	10,000min ⁻¹	D32(1.26)×0.2(0.008)	D28(1.1)×0.15(0.006)	D25(0.98)×0.1(0.004)
	10,000min ⁻¹ high-torque	D40(1.57)×0.2(0.008) D30(1.18)×0.7(0.03)	D34(1.34)×0.15(0.006) D26(1.02)×0.4(0.02)	D30(1.18)×0.15(0.006) D26(1.02)×0.25(0.01)
	16,000min ⁻¹	D24(0.94)×0.2(0.008)	D22(0.87)×0.15(0.006)	D18(0.71)×0.1(0.004)
	27,000min ⁻¹	D20(0.79)×0.2(0.008)	D19(0.75)×0.15(0.006)	D17(0.67)×0.1(0.004)
■ Tapping  Tool diameter mm (inch) × Pitch mm (inch)/rev	10,000min ⁻¹	M27 × 3.0(1-8UNC)	M24 × 3.0(7/8-9UNC)	M16×2.0(5/8-11UNC)
	10,000min ⁻¹ high-torque	M39×4.0(1 1/2-6UNC)	M33×3.5(1 1/4-7UNC)	M27×3.0(1-8UNC)
	16,000min ⁻¹	M22×2.5(7/8-9UNC)	M18×2.5(5/8-11UNC)	M14×2.0(1/2-13UNC)
	27,000min ⁻¹	M22×2.5(7/8-9UNC)	M18×2.5(5/8-11UNC)	M12×1.75(7/16-14UNC)
■ Facing  Cutting amount cm ³ /min(inch ³ /min): Cutting width mm (inch) × Cutting depth mm (inch) × Feed rate mm/min(inch/min)	10,000min ⁻¹	960 : 100×3.2×3,000 (58.6 : 3.94×0.13×118.1)	137 : 40×6.0×573 (8.4 : 1.57×0.24×22.6)	100 : 40 × 5.2 × 484 (6.1 : 1.57×0.2×19.1)
	10,000min ⁻¹ high-torque	1,700 : 100× 5.7×3,000 (102.4 : 3.94×0.22×118.1)	137 : 40×6.0×573 (8.4 : 1.57×0.24×22.6)	100 : 40 × 5.2 × 484 (6.1 : 1.57×0.2×19.1)
	16,000min ⁻¹	660 : 100×2.2×3,000 (40.3 : 3.94×0.09×118.1)	73 : 40×3.2×573 (4.5 : 1.57×0.13×22.6)	48 : 40 × 2.5 × 484 (2.9 : 1.57×0.1×19.1)
	27,000min ⁻¹	600 : 100×2.0×3,000 (36.6 : 3.94×0.08×118.1)	45 : 40×2.0×573 (2.7 : 1.57×0.08×22.6)	24 : 40 × 1.2 × 484 (1.5 : 1.57×0.05×19.1)

*The data is Brother's actual test data.

Examples of target workpieces

Automotive and motorcycle parts

- ① CVT intermediate housing
- ② Clutch case
- ③ Cylinder head cover
- ④ Cylinder block
- ⑤ EPS housing
- ⑥ Throttle body
- ⑦ Alternator
- ⑧ Starter housing
- ⑨ Crankcase
- ⑩ Cylinder head
- ⑪ Brake master cylinder

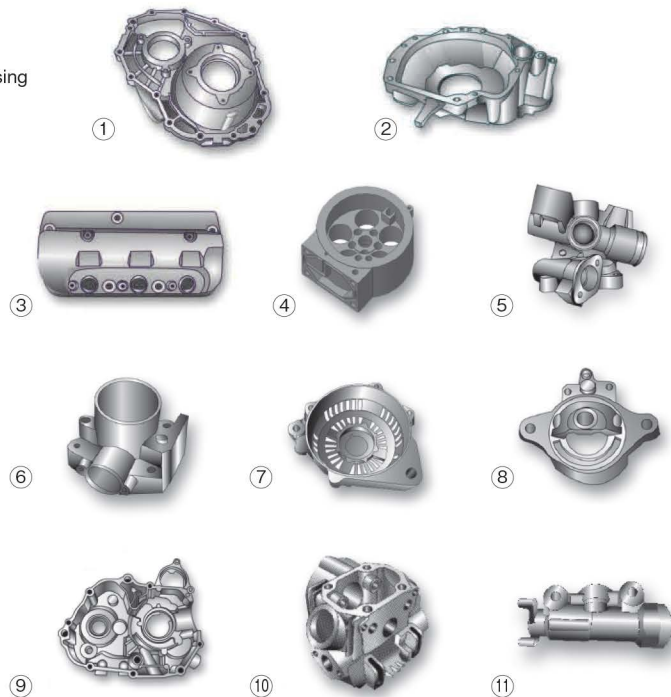

Information technology and General machinery parts

- ⑫ Mobile phone
- ⑬ Personal computer case
- ⑭ Watch parts
- ⑮ Medical implants



- Be sure to read the instruction manual and safety manual before using the product safely. If you use oil-based coolant or machine materials that may ignite, such as magnesium and resin, take thorough safety measures to prevent fire. Please contact the sales personnel for any inquiries.
- When exporting this product, carefully check the customer and their purpose of use from the viewpoint of security assurance. You may have to obtain permission from the supervisory authorities prior to export due to revisions of laws and regulations etc. Please contact Brother before exporting the machine.
- Secure 700mm (27.6inch) between machines as maintenance space.
- When exporting our product with tilting rotary table, "list control" is applicable, according to view of Ministry of Economy, Trade and Industry(METI) in Japan. Therefore, please apply for export license in advance of export. If necessary, please contact METI,



**SPEEDIO™
S500X1**

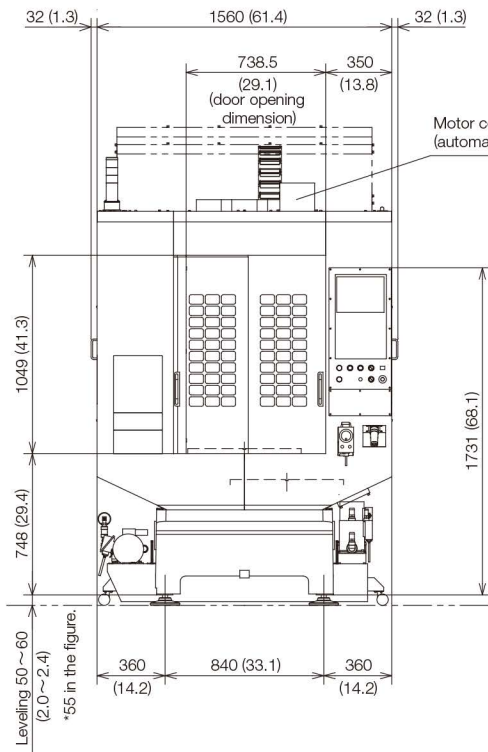
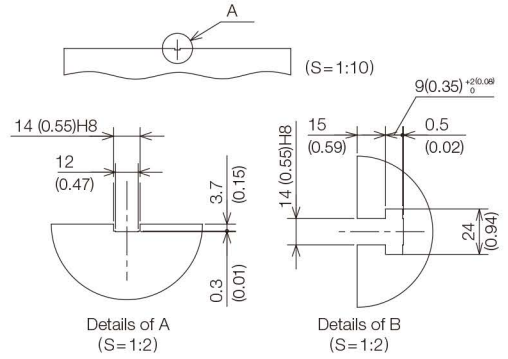
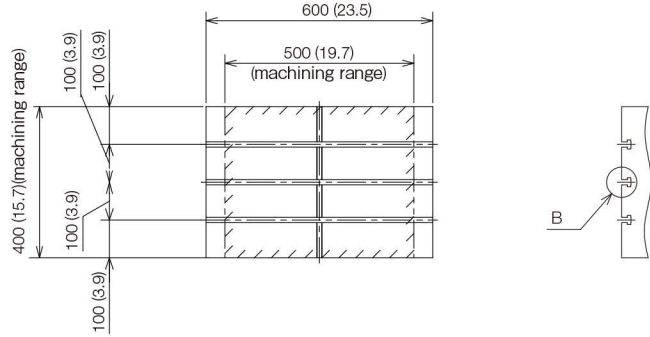
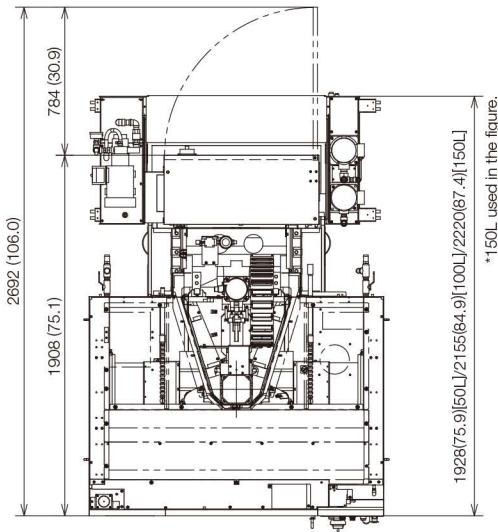

444 (17.5) (Magazine cover)
21-tool High column 150 / 21-tool High column 250
254 (10) (Magazine cover)
14-tool High column 150 / 14-tool High column 250
21-tool standard column

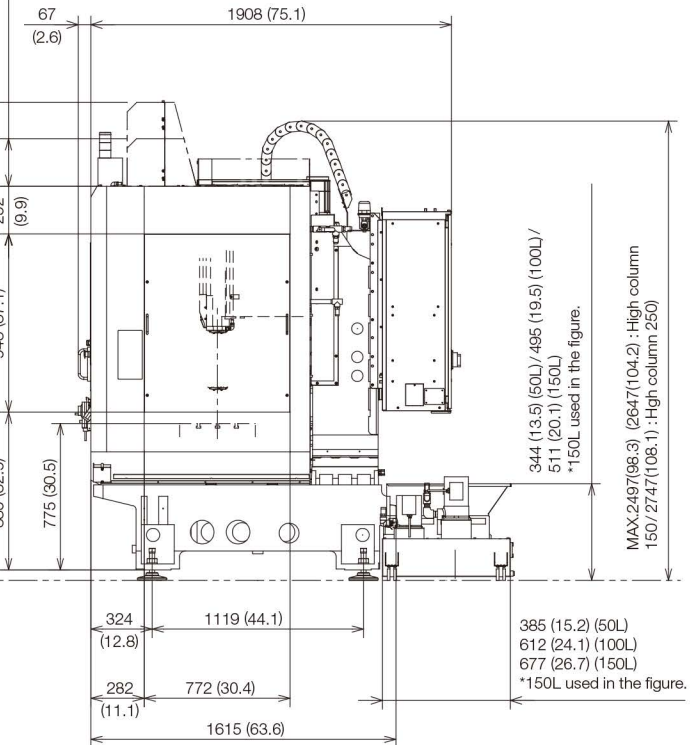

MAX. 2497 (98.3) (2647 (104.2) : High column
150 / 2747 (108.1) : High column 250

385 (15.2) (50L)
612 (24.1) (100L)
677 (26.7) (150L)
*150L used in the figure.

mm (inch)

SPEEDIO™ S700X1

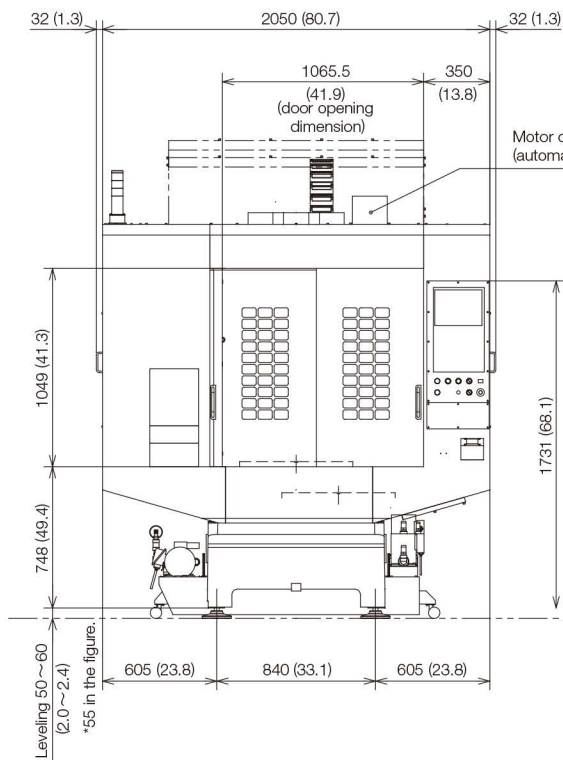
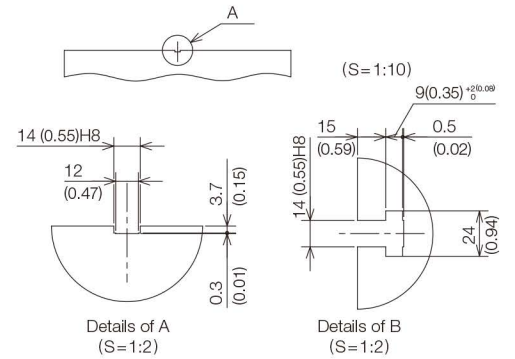
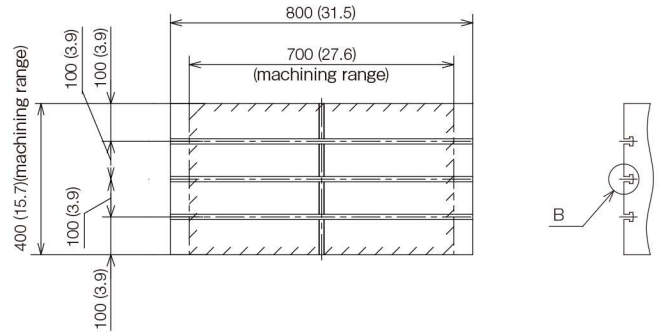
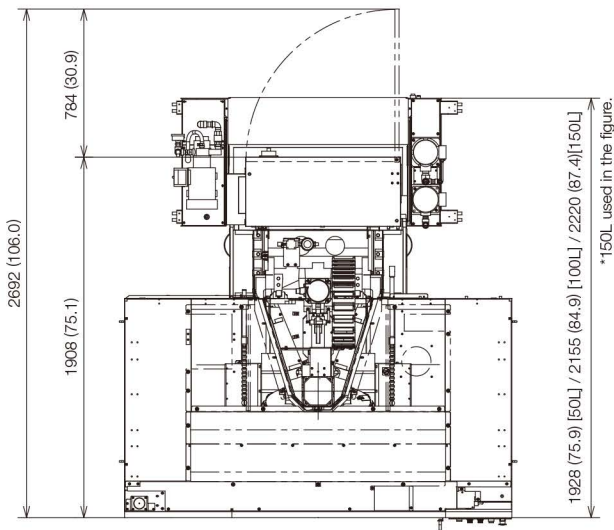

444 (17.5) (Magazine cover)
21-tool High column 150 / 21-tool High column 250
254 (10) (Magazine cover)
14-tool High column 150 / 14-tool High column 250
21-tool standard column

Motor cover
(automatic door type)

67 (2.6)

1908 (75.1)

252 (9.9)

943 (37.1)

835 (32.9)

775 (30.5)

344 (13.5) (50L) / 495 (19.5) (100L) / 511 (20.1) (150L)
*150L used in the figure.

MAX.2497 (98.3) (2647 (104.2) High column 150 / 2747 (108.1) High column 250)

385 (15.2) (50L)
612 (24.1) (100L)
677 (26.7) (150L)
*150L used in the figure.

324 (12.8)

1119 (44.1)

282 (11.1)

772 (30.4)

1615 (63.6)

mm (inch)



Working with you for a better environment
www.brotherearth.com

Global Service Sites

Local dealers are available to provide services in each region, in addition to the sites below.

U. S. A.

**BROTHER INTERNATIONAL CORP.
MACHINE TOOLS DIV. TECHNICAL CENTER**
2200 North Stonington Avenue, Suite 270, Hoffman Estates, IL 60169, U.S.A.
PHONE:(1)224-653-8415 FAX:(1)224-653-8821

Thailand

**BROTHER COMMERCIAL THAILAND LTD.
MACHINE TOOLS TECHNICAL CENTER**
1232 Rama 9 Road, Suanluang Sub-District, Suanluang District,
Bangkok 10250, Thailand
PHONE:(66)2-374-6447 FAX:(66)2-374-2706

China

**BROTHER MACHINERY (SHANGHAI) LTD.
(MACHINE TOOLS DIV.) SHANGHAI TECHNICAL CENTER**
3F, Haiyi Commercial bldg. No.310 TianShan Road, ChangNing District,
Shanghai 200336, China
PHONE:(86)21-3251-9837 FAX:(86)21-3251-9839

Germany

**BROTHER INTERNATIONALE INDUSTRIEMASCHINEN GmbH
MACHINE TOOLS DIVISION FRANKFURT TECHNICAL CENTER**
Hoechst Str.94, 65835 Liederbach, Germany
PHONE:(49)69-977-6708-0 FAX:(49)69-977-6708-80

India

**BROTHER INTERNATIONAL (INDIA) PVT LTD.
BANGALORE TECHNICAL CENTER**
Park Landing, Ground Floor, Municipal No.5AC-709, 2nd Block, HRBR Extension,
Bangalore - 560 043 Karnataka, India
PHONE:(91)80-6405-7999

China

**BROTHER MACHINERY (SHANGHAI) LTD.
DONGGUAN BRANCH (MACHINE TOOLS DIV.) DONGGUAN TECHNICAL CENTER**
1F, No.45 North Road Lianfeng, Xianxi Village, Chang'an Town, Dongguan,
Guangdong Province, China
PHONE:(86)769-2238-1505 FAX:(86)769-2238-1506

Figures in brackets () are the country codes.

Specifications may be subject to change without any notice.

brother®

BROTHER INDUSTRIES, LTD.
MACHINERY & SOLUTION COMPANY

1-5, Kitajizoyama, Noda-cho, Kariya-shi,
Aichi-ken 448-0803, Japan
PHONE: 81-566-95-0075
FAX : 81-566-25-3721

<http://www.brother.com>